

Kiln Controller Handbook



Issue: 1.0
Date: 23 Aug 2014

Stafford Instruments Ltd.
Unit 22 Wolseley Court
Staffordshire Technology Park
Stafford
Staffordshire
ST18 0GA.
United Kingdom

Tel: +44 (0)1785 255588
Fax: +44 (0)1785 255589
www.staffordinstruments.co.uk
email: sales@staffordinstruments.co.uk

© Copyright 2014 Stafford Instruments Ltd.

Further copies of this document can be found at www.staffordinstruments.co.uk/docs/st220/user222A.pdf

Contents

Features.....	2
Quick Start Guide	3
Programming	4
Firing.....	5
At A Glance.....	6-7
Adjusting While Firing.....	8-9
Errors	10
Specification.....	11
Notices	12

Features

- Ideal for glass or ceramics use
- 9 programs each with up to 9 segments
- 1 controlled heating / cooling ramp + soak per segment
- Heating and Cooling indicators
- Programs can be altered while firing
- Program pause & advance facilities
- Delayed start facility
- Power failure recovery
- kWh energy used display
- Selectable °C/°F Operation
- Alarm buzzer
- Easy to deploy % extension lead+type format

Quick Start Guide

Refer to the At a Glance centre page of this handbook for a description of the controls
Switch on & wait for kiln temperature display
To run a firing program set up previously press the START key. If you do not want a start delay the ST222A will start firing after 5 seconds
To stop firing at any time press the STOP key again
To review firing data press the ENTER key to enter the programming menu
To change firing data press the UP & DOWN keys to change the displayed value
Use the ENTER key again as necessary to move to the next firing value or segment to be reviewed or changed
To mark the end of a program set a ramp rate to End with the STOP key
To exit the programming menu either wait 10 seconds or press the START key to start firing

Programming

Press the **STEP** key to display the currently selected (flashing) program number. This can be changed as required with the **UP** or **DOWN** key. There are 9 fully adjustable programs available.

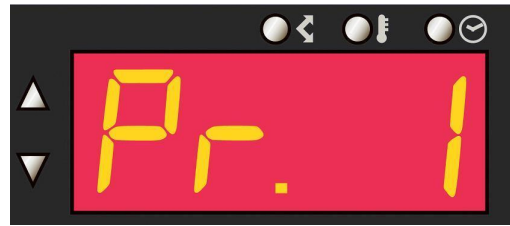

Note: the SEGMENT display shows: "1". The firing parameters for segment 1 can now be entered as detailed below:-

Press the **STEP** key again. The ramp rate in °/hr is now shown. This can be changed as required with the **UP** or **DOWN** key in the range 1 to 999°/hr + FULL. **Note: hold UP or DOWN key down to get accelerated change of the displayed value.**



Press the **STEP** key again. The soak temperature in ° is now shown. This can be changed as required with the **UP** or **DOWN** key. **Note: the maximum temperature available will be limited by the kiln type. Hold UP or DOWN key down to get accelerated change of the displayed value.**



Press the **STEP** key again. The soak time in hours.minutes is now shown. This can be changed as required with the **UP** or **DOWN** key in the range 00.00 (no soak) up to nearly 100 hours. **Note: hold UP or DOWN key down to get accelerated change of the displayed value.**



Press the **STEP** key again. The SEGMENT display now shows: %End+. Data for this and other subsequent segments can now be entered as detailed above (maximum of 9 segments). If no further segments are required then, while entering a ramp rate, hold down the **DOWN** key until %End+ is displayed.

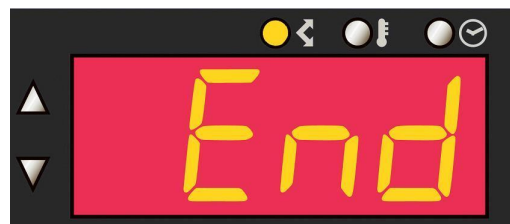

Explanation: the full range of displayed values for ramp rate are: End, 1...999°/hr, FULL. To mark the end of a program select a ramp rate of "End" by holding down the DOWN key until End is displayed. To add an extra segment press the UP key until your desired ramp rate is shown. If you want to heat at full power hold down the UP key until FULL is displayed.

Note: at any time the programming sequence can be terminated either by pressing the RUN key or by waiting 20 seconds without pressing any keys.

Firing

Press the **START** key. The display will show 00.00. The RUN INDICATOR and the TIME INDICATOR will flash, prompting you to enter an (optional) delayed start (use the **UP** key). If no delay is entered the firing will start in 5 seconds (or immediately if the **START** key is pressed again).



During heating the HEATING INDICATOR will be lit (as shown). The kiln temperature is displayed and it will ramp up until the programmed soak temperature is reached. The KILN ON indicator shows when power is actually being applied to the kiln.

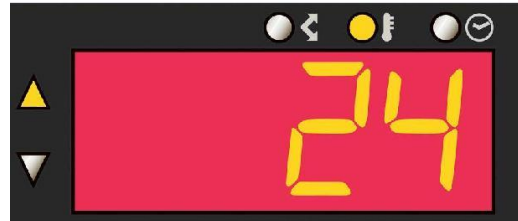

When the kiln reaches the programmed soak temperature both the HEATING INDICATOR and the COOLING INDICATOR will be off. The kiln remains soaking for the programmed soak time. The display alternates between showing kiln temperature ...



and showing the soak time remaining.



During cooling the COOLING INDICATOR will be lit (as shown). The kiln temperature is displayed and it will ramp down until the programmed soak temperature is reached. The KILN ON indicator shows when power is actually being applied to the kiln.

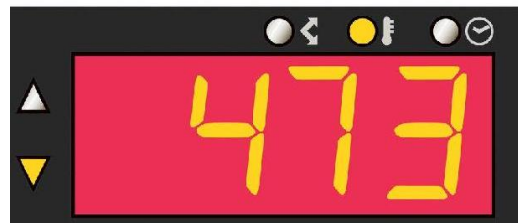

At the end of the firing program the display will show %End+and both the HEATING INDICATOR and the COOLING INDICATOR will be lit. This display will alternate with the actual kiln temperature. To cancel this display either press the **STOP** key or turn the controller off.



At any time during or after firing, the energy used by the kiln in kWh is displayed by pressing and holding down both the **UP** key and the **DOWN** key. **Note: the energy used display is reset to zero when the START key is pressed.**

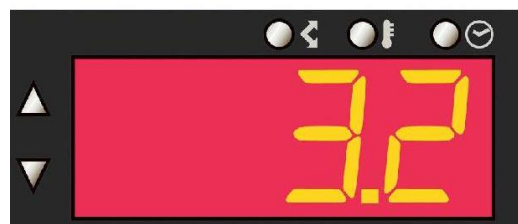

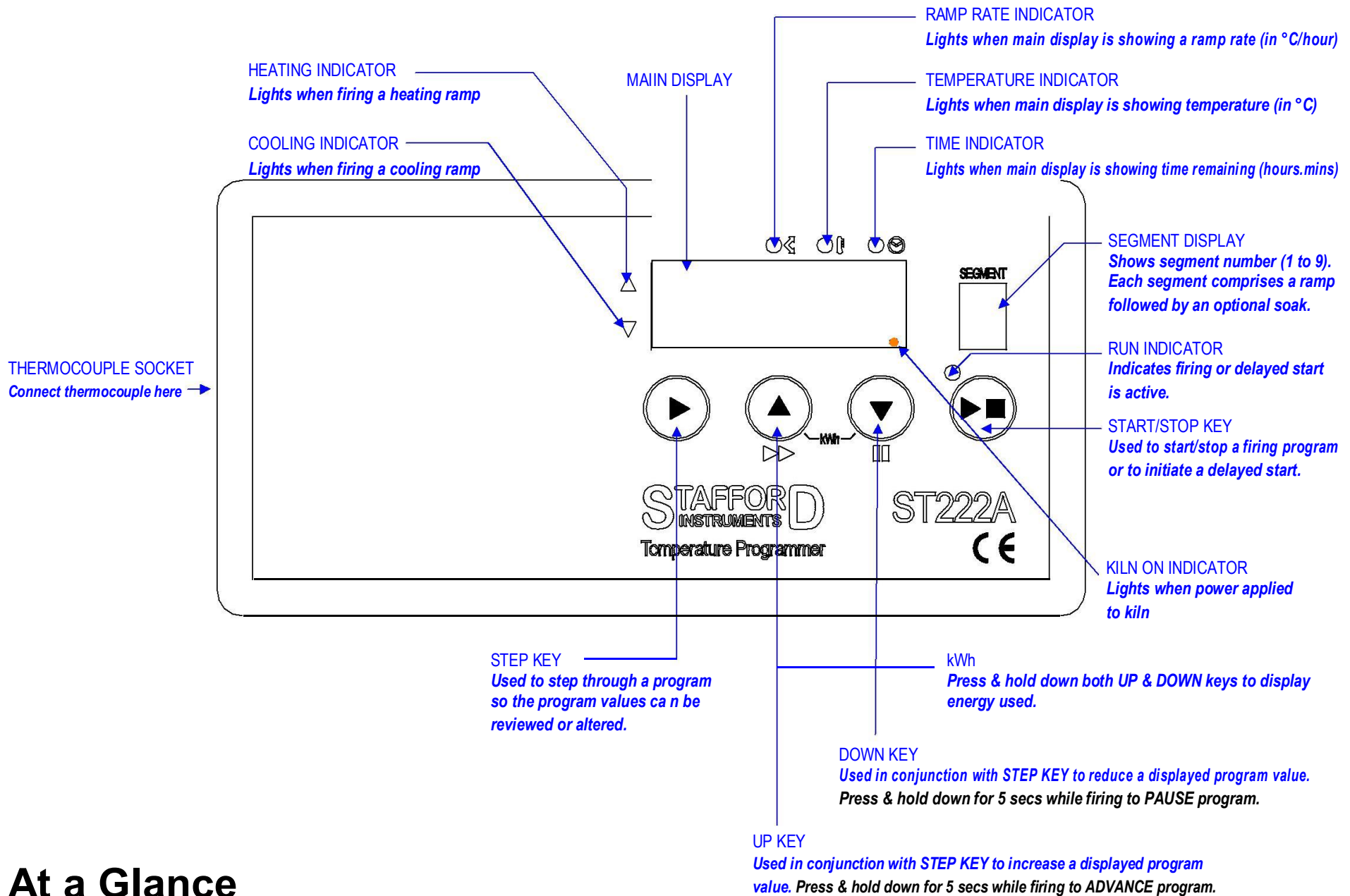

At a Glance

Adjusting While Firing

Firing values can be adjusted during a firing. Also there are program pause and program advance features that are particularly useful for glass work.

Adjusting Firing Values

While firing operate the **STEP** key to select the firing parameter that needs to be changed. Note that the program number cannot be changed while firing. Also only the current segment or segments not yet fired can be changed while firing. Firing will still carry on as normal while these changes are being made. The controller will return to its normal running display 10 seconds after key presses cease (or immediately after End is displayed).

Changes made to programs in this way are stored and are used for subsequent firings.

Program Advance Facility

While firing press and hold down the **UP** key for about 4 seconds until the controller beeps. The executing program will immediately advance one step as follows:-

If a start delay is currently executing then the controller will terminate this and start firing immediately.

If ramping is currently executing then the controller will switch to soak at the current kiln temperature.

If currently soaking then the controller will advance to the next segment if any, or else it will end the firing.

Changes made to the operation of the controller in this way are temporary and are not stored.

Program Pause Facility

While firing press and hold down the **DOWN** key for about 4 seconds until the controller beeps. The controller will pause the executing program. To un-pause the program press and hold down the **DOWN** key again for about 4 seconds (until the controller beeps). The effects of pausing are as follows:-

If paused during ramping the kiln temperature will be held (soaked) **indefinitely** at the current kiln temperature. The ramp will continue when un-pause is selected.

If paused during soaking then the soak time will be **extended indefinitely**. The remainder of the soak period will be resumed when un-pause is selected.

Program advance (**UP** key held down for about 4 seconds until the controller beeps) can also be used to terminate a pause. If paused while ramping then will cause the controller to go into soak at the current kiln temperature. If paused while soaking then will cause the controller to move onto the next segment.

Changes made to the operation of the controller in this way are temporary and are not stored.

While paused, a warning double beep is sounded every 30 seconds and PAUSEd is scrolled across the display.

WARNING - PROGRAM PAUSE

The program pause facility should be used with care. Program execution is suspended and the kiln will be held at its current temperature indefinitely.

If left too long at high temperatures kiln damage could result.

Errors

In the event of an error condition the controller will display an error code and sound its alarm buzzer. The firing will be aborted. Make a note of the error number then

SWITCH OFF THE KILN & THE CONTROLLER



Error	Meaning	Possible Cause / Remedy
1	Kiln temperature not increasing as required. The kiln has been on full power for some time but the temperature has not increased as expected.	Heater element failure. Low mains voltage. Kiln door not closed properly. Controller relay failure (open circuit).
2	Thermocouple or thermocouple wiring open circuit.	Check thermocouple wiring and connector. If wiring OK then fit new thermocouple.
3	Thermocouple reversed.	Thermocouple wiring fault.
4	Kiln temperature too high. Kiln has been on zero power for some time but the kiln temperature has not decreased as expected.	Controller relay failure (short circuit). Thermocouple accidentally pushed out of kiln.
5	Kiln temperature overshoot.	Fire in kiln, paper clay, lost wax casting exotherm etc.
6	Maximum firing time limit exceeded.	Contact manufacturer or supplier.
7	Maximum room temperature limit exceeded.	Work room too hot. Work room fire. Contact manufacturer or supplier.

Specification

Electrical

Power supply

Voltage range: 100 - 253V
Frequency: 50/60 Hz
Phases: 1
Power switched: 3kW (max)

Fuse: 13A fuse in plug
(BS1363)
(UK version only)

Control Relay

Contact type: SPST NO
@13A max

Thermocouple

R,S,K & N type.

Enclosure

Material: ABS (Flameproof)
Colour: Black
Size: 173mm x 85.6mm x 43.5mm
(less mains cable and gland)
Weight: 652g (approx)

Environmental

Location: For indoor use only
RH: Maximum relative humidity 80 % for temperatures up to 31°C decreasing linearly to 50 % relative humidity at 50°C
Operating Temperature: 0°C to +50°C
Storage Temperature: -10°C to +55°C
Sealing: IP40
Pollution Class: 2
Installation Category: II

Temperature

Temperature setting

Range: 0 to 1320°C (R/S)
0 to 1200°C (K/N)

Resolution: 1°C

Control Accuracy

P.I.D. Control
Reading accuracy: $\pm 0.25\%$ FSD
 ± 1 digit

Time

Start delay range: 00:00 to 99hr 59min
Soak time range: 00:00 to 99hr 59min
Resolution: 1 min

Ramps

Ramp rate: 1 to 999°/hour or full power
Ramps can be heating or cooling

Error Handling

Thermocouple failure detection
Thermocouple reversal detection
Heater failure detection
Kiln over-temperature detection
Room over-temperature detection
Firing run time hours limiter
Alarm buzzer

Other

Kiln heating indicator
Program running indicator
Selectable °C/°F operation

Notices

Compliance



Complies with Council
Directives:-2006/95/EC (Safety)
89/336/EC (EMC)

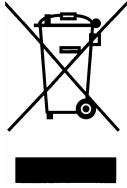

Council Directives 2002/96/EC & 2003/108/EC

The crossed out bin symbol, placed on this product, reminds you of the need to dispose of the product properly at the end of its life. Electrical & Electronic Equipment should never be disposed of with general waste but must be separately collected for proper treatment. In this way you will assist in the recovery, recycling & reuse of many of the materials used in this product.

Warning



Ensure that thermocouple is correctly inserted into the kiln before firing! The end of the thermocouple should protrude into the firing chamber by at least 10mm. Failure to ensure this may result in over-firing!